

# CHECK VALVES

without/with pilot control, hydraulically pilot operated, pmax. 500 bar

## Description:

These hydraulic check valves are part of the spring loaded shut-off valves. The check valves serve for blocking the supply line in the application of leak-free hydraulic cylinders in combination with low leaking directional valves.

## Functionality:

The flow **B**→**A** is permanently open. In the opposite direction **A**→**B** the flow is locked. It can be unlocked by pressurizing the control port **Z**. The minimum pressure for that depends on the pressure load at port **A**.

The check valve with a capacity of 20 l/min is not equipped with a pilot control. The valve with a capacity of 50l/min is optional available without or with pilot control.

In application with higher pressure and volume flow we recommend check valves with pilot control.

The pilot control is effected by unlocking a seat valve in the main valve piston. Thereby a lesser control pressure is required to unlock the flow.

By using a pilot control also clamping cylinders with unfavorable area ratio can be used.

The pressure drop in the consumer line takes place gradually. This prevents from decompression shocks and preserves the connected hydraulic elements.

## Operating conditions:

By their design with manifold connection the check valves without/with pilot control facilitate fixtures without piping.

Uncoupled machine parts e.g. pallet systems can be kept pressurized by using these shut-off valves.

## Important notice:

Faults can occur in the pressure ratio if the pressure load is too low to unlock the valve. This can effect dangerous malfunctions when decompressing swing clamp cylinders and pull cylinders.

Such clamping cylinders must be operated with check valves equipped with pilot control. These valve types are designed for a much lower control pressure.

To relieve the piston chamber, a drain connection is required. This must be protected from ingress of dirt and liquids.



Webcode: 070011

Other designs are available on request

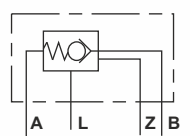

## Advantages:

- ☒ Installation without piping
- ☒ Pilot control prevents from decompression shocks
- ☒ Allows pressure maintenance at uncoupled machine parts

## Application example:

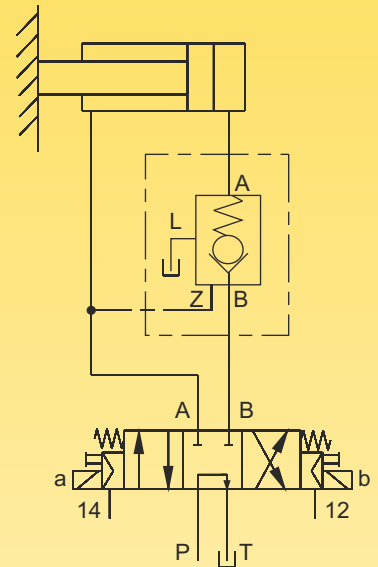

## Schematic symbols:

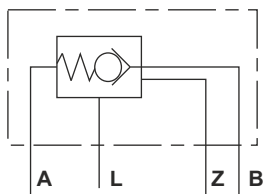

Without pilot control

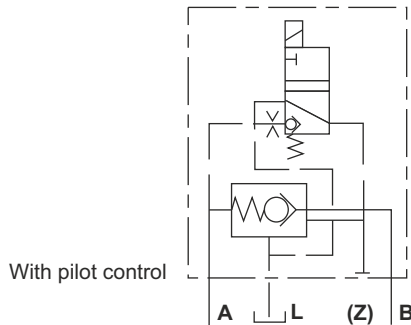

With pilot control

Minimum pressure **p<sub>Z</sub>** to unlock at pressure **p<sub>A</sub>** (**p<sub>B</sub>** = 0 bar)

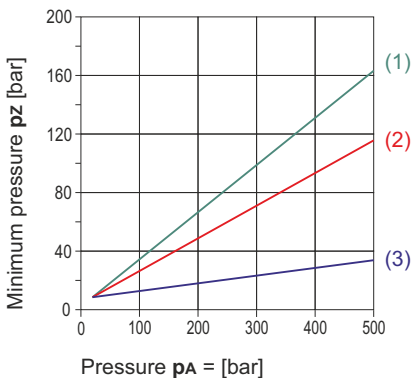

- (1) Order no. ERSV-500-5-003
- (2) Order no. ERSV-500-8-001
- (3) Order no. ERSV-500-8-002 (with pilot control)

Δp-Q nominal line

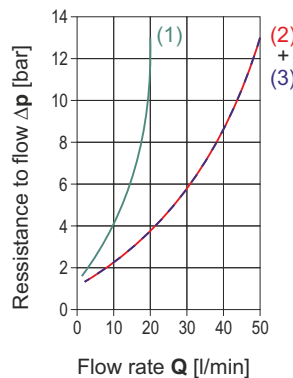

Oil viscosity at measurement 60 mm<sup>2</sup>/s

**HYDROKOMP**  
Hydraulische Komponenten GmbH

Siemensstraße 16, 35325 Mücke (Germany)  
Phone: +49 6401 225999-0  
Fax: +49 6401 225999-50  
E-mail: info@hydrokomp.de  
Internet: www.hydrokomp.de

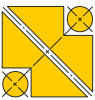

## Check valves

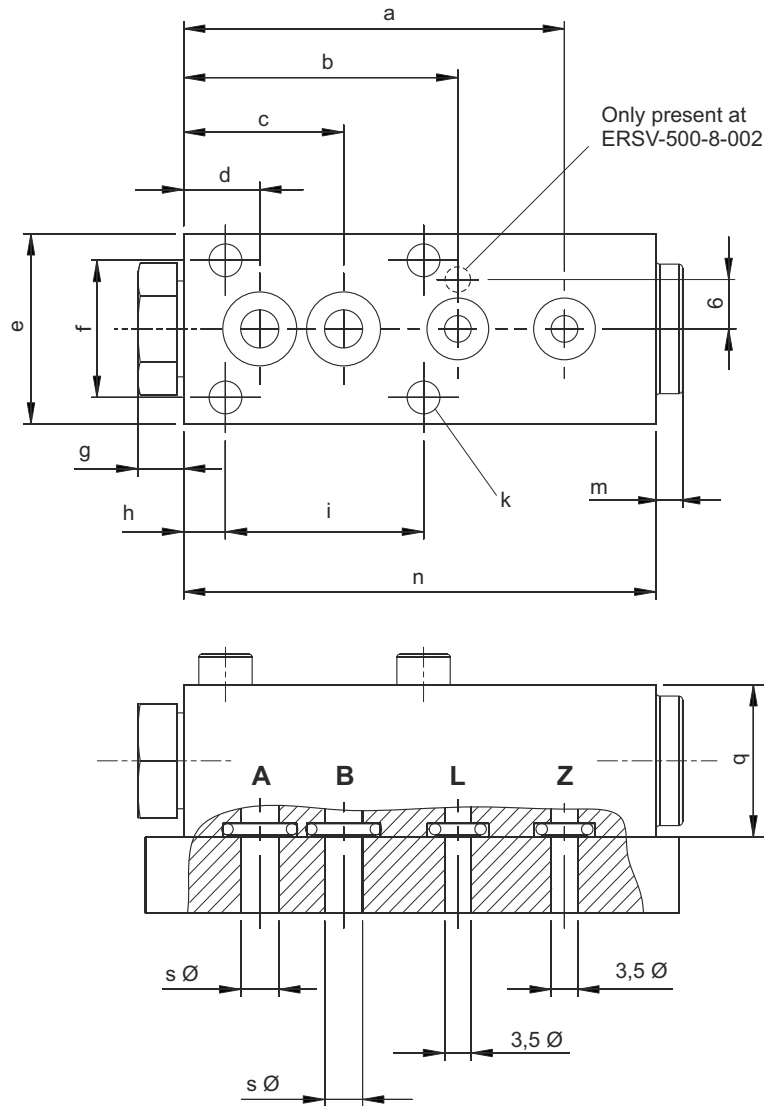

### Technical data:

Type		Without pilot control	Without pilot control	With pilot control
Max. volume flow ( $Q_{max.}$ )	[l/min]	20	50	50
Max. operating pressure (A, B, Z)	[bar]	500	500	500
Port (L)		depressurised	depressurised	depressurised
Control volume	[cm <sup>3</sup> ]	0,2	0,5	0,5
Control volume pz ( $p_B = 0$ )	[bar]	$(0,32 \times p_A) + 4$	$(0,22 \times p_A) + 4$	$(0,05 \times p_A) + 4$
Unlock ratio ( $p_A/p_Z$ )		1 : 2,9	1 : 4,3	1 : 4,3
Mounting screws <sup>(1)</sup>	[4 pce.]	M4x25	M6x40	M6x40
Tightening torque	[N/m]	2,6	9	9
a	[mm]	50	56	56
b	[mm]	36	42	42
c	[mm]	21	31	31
d	[mm]	10	13	13
e	[mm]	25	35	35
f	[mm]	18	25	25
g	[mm]	9	9	9
h	[mm]	5,5	9	9
i	[mm]	26	26	26
k	[mm]	M4x5 deep	M6x10 deep	M6x10 deep
m	[mm]	3,5	4	4
n	[mm]	62	70	70
q	[mm]	20	35	35
s $\emptyset$	[mm]	5	9	9
O-rings <sup>(1)</sup> (A, B)	[mm]	6,07 x 1,78	9,19 x 2,62	9,19 x 2,62
O-rings <sup>(1)</sup> (L, Z)	[mm]	4,47 x 1,78	4,47 x 1,78	4,47 x 1,78
Weight approx.	[kg]	0,30	0,70	0,70
Order no.:		ERSV-500-5-003	ERSV-500-8-001	ERSV-500-8-002

<sup>(1)</sup>Scope of supply includes mounting screws and O-rings.